

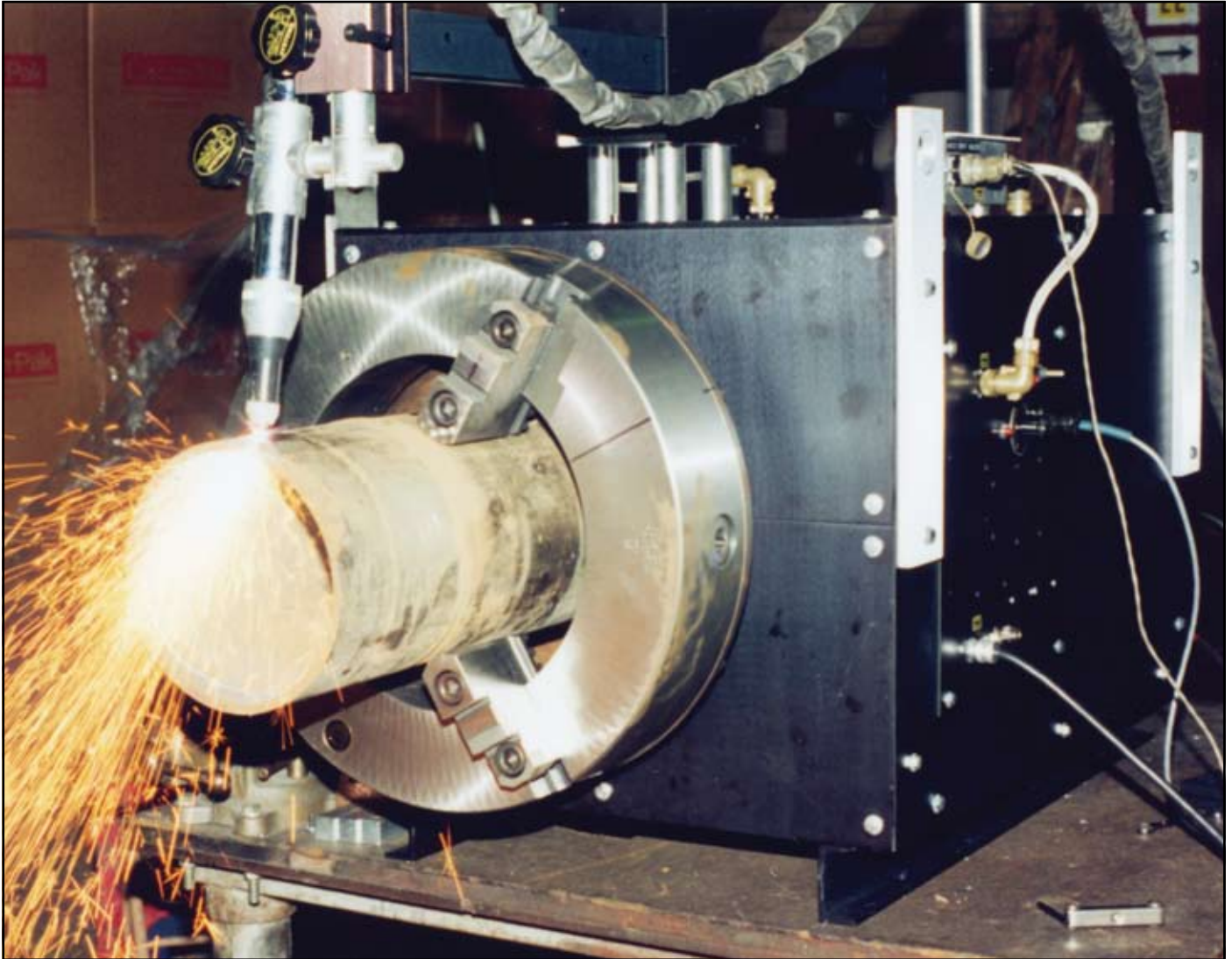

SE-4PD, SE-2PTD
& SE-4PTD

**Programmable Saddle, Elbow
and Shape Cutter for Pipes.**

Now you can make Saddle Cuts, Offset Cuts, Laterals, Miters, Holes and Shapes quickly, easily, and economically.



The Programmable SE-4PD, SE-2PTD and SE-4PTD Machines provide dual programming capabilities. A "Pipe" program for making Saddle Cuts, Offset Cuts, Laterals and Miters. A second (selectable) program is used for cutting customized shapes in pipes. These machines are available for plasma or oxy-fuel cutting and eliminate the need to make templates or layout complex cuts.



CYPRESS WELDING EQUIPMENT INC.

CE

A DIVISION OF WELD TOOLING CORPORATION

280 Technology Drive • Canonsburg, PA 15317-9564 USA
Telephone: 1-412-331-1776 • 1-800-245-3186 • Fax: 1-412-331-0383
<http://www.cypressweld.com>

MODEL SE-2PTD

PLASMA VERSION:

PART NUMBER	DESCRIPTION
SEO-4250-PL	SE-2PTD 120V Plasma
SEO-4252-PL	SE-2PTD 240V Plasma

OXY-FUEL VERSION:

PART NUMBER	DESCRIPTION
SEO-4250-OX	SE-2PTD 120V Oxy-fuel
SEO-4252-OX	SE-2PTD 240V Oxy-fuel

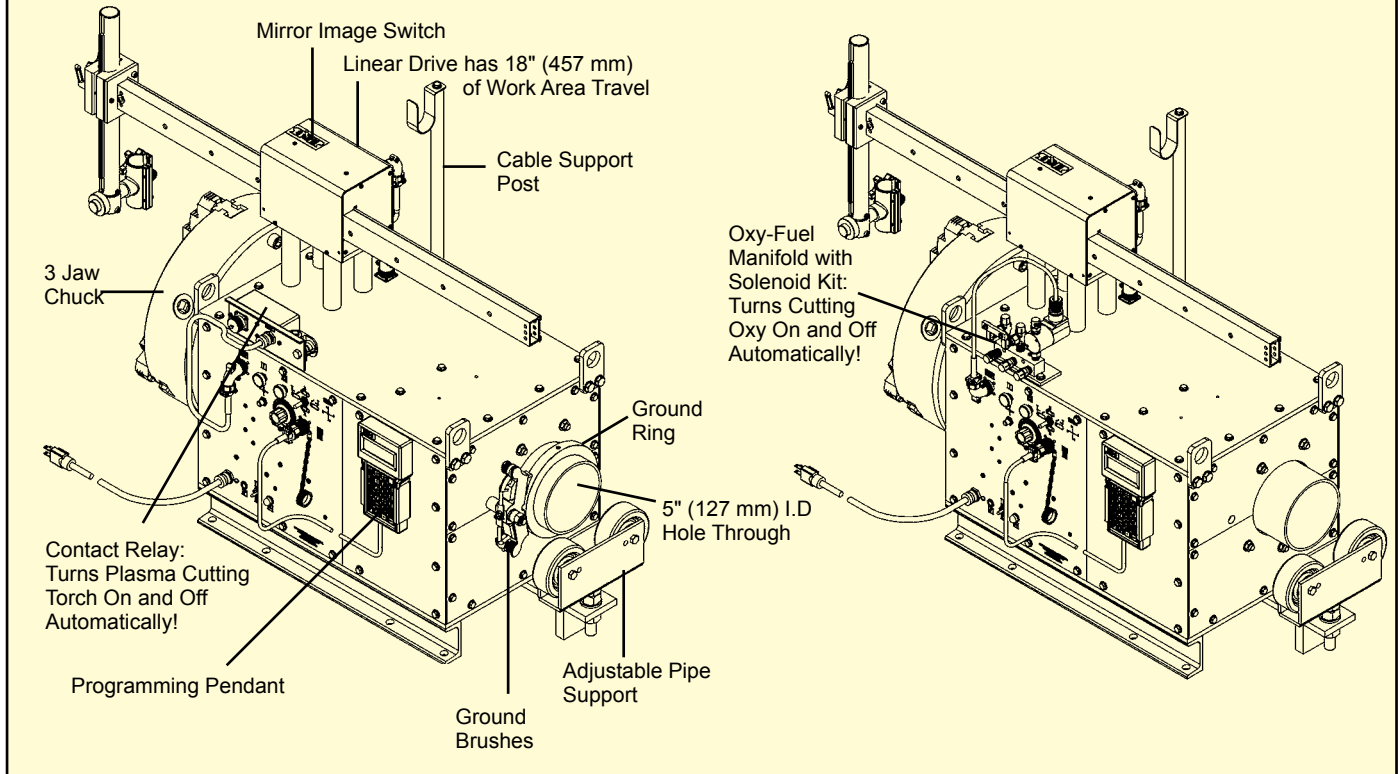

Technical Data:

Cutting Diameter:	Pass through 1" to 4 3/4" (25 mm to 120 mm) O.D.
Rotation Speed:	Min: 0.3 rpm Max: 3.7 rpm
Dimensions:	40"L x 19"W x 35"H (1016 x 483 x 889 mm)
Input Power:	120/50-60/1 or 220/50-60/1
Net Weight:	345 lbs. (157 kg)
Shipping Weight:	420 lbs. (191 kg)
Types of Cuts:	
Pipe Program:	<ol style="list-style-type: none"> 1. Saddle Cuts 2. Offset (Hillside) 3. Laterals 4. Miter Cuts, Single Cut 3. Piece Elbow 5. Hole Cuts
Shape Program:	Standard Any Arbitrary Shape

Capacity:
Max Weight: 375 lbs. (170 kg)
 (pass through, when supported).

Short sections of pipe up to 16" (406 mm) dia. can be mounted off the chuck face.

Max Overhung Length: 15" (383 mm)
Max Overhung Weight: 150 lbs. (68 kg)

When using the pass through feature the max weight of the pipe should not exceed 375 lbs. (170 kg). It is very important to have your pipe supports in alignment with the machine to support the pipe in the back of the machine.

The machine is designed to sit on a work table. Method of cutting can be oxy-fuel or plasma. If oxy-fuel is used, the machine will be equipped with solenoids and a three hose cutting torch. When plasma is used, a rotary ground is installed on the machine and an external contactor relay. The machine can be delivered with plasma torch leads and power source, or the customer may provide their own plasma equipment.

MODEL SE-4PTD

PLASMA VERSION:

PART NUMBER	DESCRIPTION
SEO-4400-PL	SE-4PTD 120V Plasma
SEO-4402-PL	SE-4PTD 240V Plasma

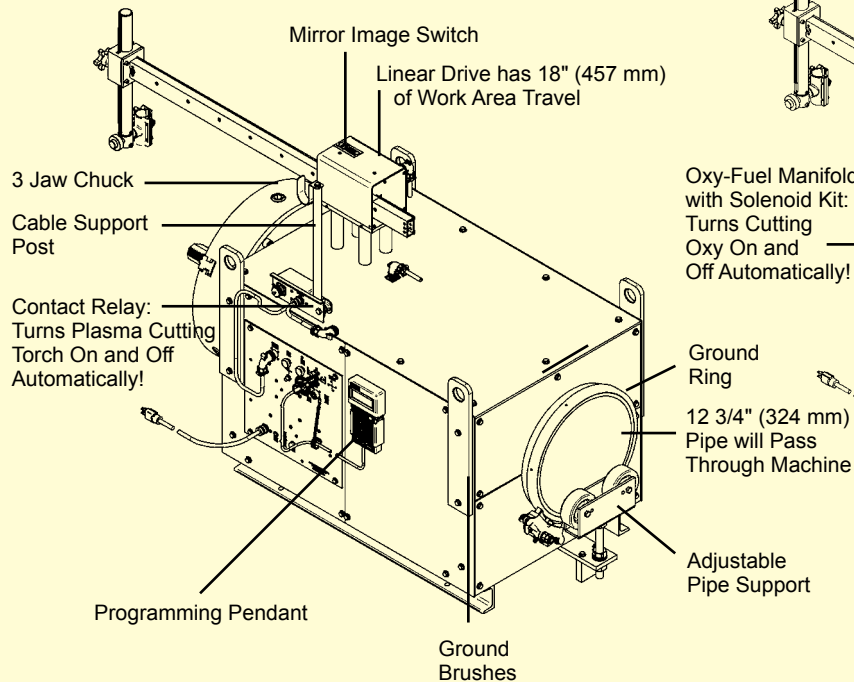

OXY-FUEL VERSION:

PART NUMBER	DESCRIPTION
SEO-4400-OX	SE-2PTD 120V Oxy-fuel
SEO-4402-OX	SE-2PTD 240V Oxy-fuel

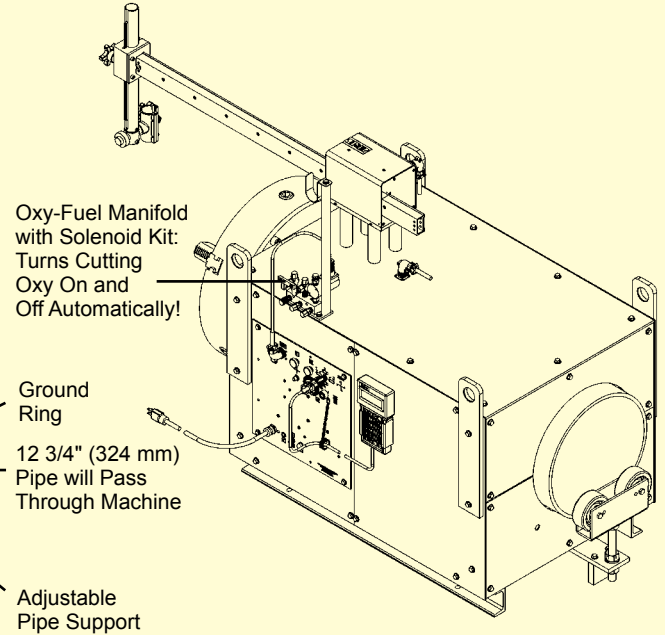

Technical Data:

Cutting Diameter: Pass through 4"-12 3/4" O.D. (100 mm to 325 mm).

Internal chucking of pipe (for short lengths) up to 20" (500 mm) diameter.

Rotation Speed: **Min:** 0.2 rpm
Max: 3 rpm

Dimensions: 52 1/2"L x 24 1/4"W x 33"H (1334 x 616 x 838 mm)

Input Power: 120/50-60/1 or 220/50-60/1

Net Weight: 705 lbs. (320kg)

Shipping Weight: 900 lbs. (409 kg)

Types of Cuts:

- Pipe Program:**
1. Saddle Cuts
 2. Offset (Hillside)
 3. Laterals
 4. Miter Cuts, Single Cut
 3. Piece Elbow
 5. Hole Cuts

Shape Program: Standard
Any Arbitrary Shape

Max Length: 18" (460 mm)

Max Weight: 375 lbs. (170 kg)

When using the pass through feature the max weight of the pipe should not exceed 375 lbs. (170 kg). It is very important to have your pipe supports in alignment with the machine to support the pipe in the back of the machine.

The machine is designed to sit on a work table. Method of cutting can be oxy-fuel or plasma. If oxy-fuel is used, the machine will be equipped with solenoids and a three hose cutting torch. When plasma is used, a rotary ground is installed on the machine and an external contactor relay. The machine can be delivered with plasma torch leads and power source, or the customer may provide his own plasma equipment.

MODEL SE-4PD

PLASMA VERSION:

PART NUMBER	DESCRIPTION
SEO-4520-PL	SE-4PD 120V Plasma
SEO-4522-PL	SE-4PD 240V Plasma

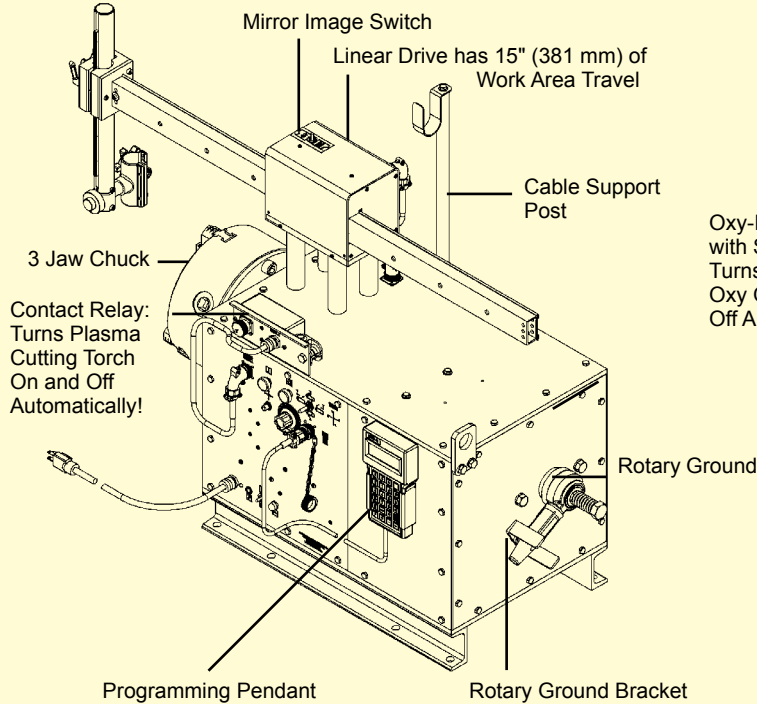

OXY-FUEL VERSION:

PART NUMBER	DESCRIPTION
SEO-4520-OX	SE-4PD 20V Oxy-fuel
SEO-4520-OX	SE-4PD 240V Oxy-fuel

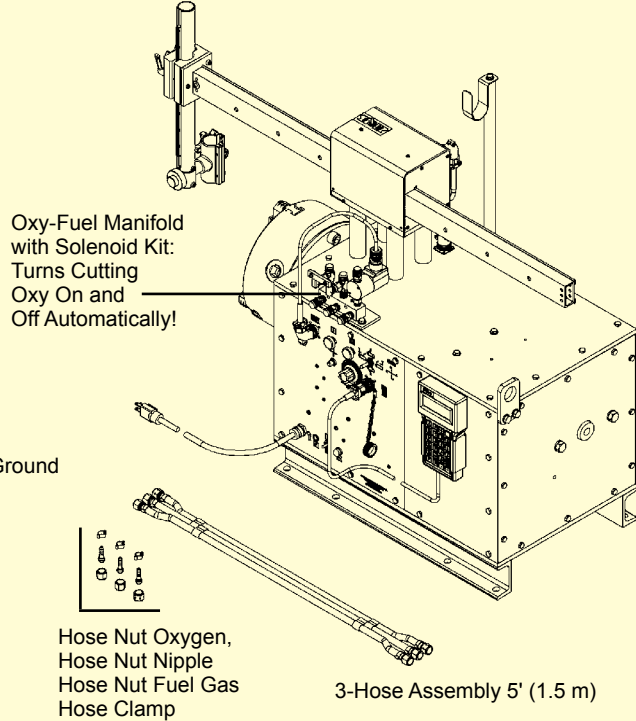

Technical Data:

Cutting Diameter:	1"-12" O.D. (25 mm to 304 mm).
Rotation Speed:	Min: 0.2 rpm Max: 3.7 rpm
Dimensions:	38"L x 15.25"W x 22.25"H (965 x 387 x 565 mm)
Input Power:	115 VAC
Net Weight:	200 lbs. (91kg)
Shipping Weight:	300 lbs. (136 kg)
Types of Cuts:	
Pipe Program:	<ol style="list-style-type: none"> 1. Saddle Cuts 2. Offset (Hillside) 3. Laterals 4. Miter Cuts, Single Cut 3. Piece Elbow 5. Hole Cuts
Shape Program:	Standard Any Arbitrary Shape
Capacity:	100 lbs. (45.36 kg)

The SE-4PD is a computer-controlled machine that automates the cutting of profiles, holes, nozzles and shapes on pipe with diameters from 1" to 12" (2.54-30.48 cm). It rotates the pipe on it's roller bed with a three jaw chuck while simultaneously moving a cutting torch back and forth along the pipe's axis. Pre-programmed shapes such as saddle, hillside, lateral and miter cuts can be made by simply selecting the type of cut from the menu, then entering the diameters of the pipe being processed and pressing the run button to cut your pipe. No need for templates. No time consuming layout or calculations to do. In addition irregular or uncommon shapes can be plotted, programmed and saved for future use.

The machine is designed to sit on a work table. Method of cutting can be oxy-fuel or plasma. If oxy-fuel is used, the machine will be equipped with solenoids and a three hose cutting torch. When plasma is used, a rotary ground is installed on the machine and an external contactor relay. The machine can be delivered with plasma torch leads and power source, or the customer may provide his own plasma equipment.

ACCESSORY KITS

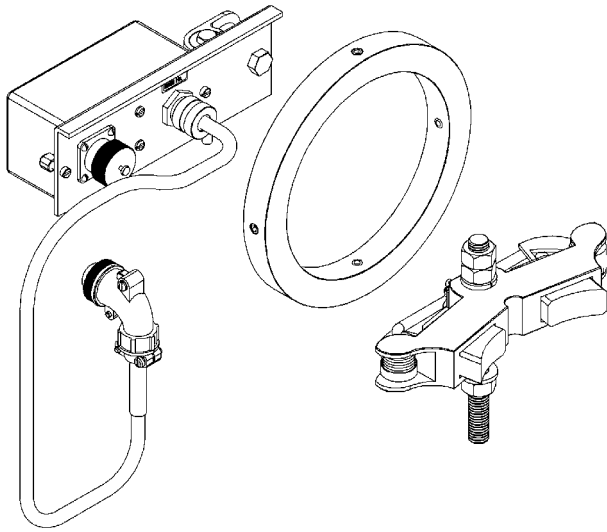

PLASMA KIT

The Plasma Kit enables you to convert the machine to use a plasma cutting process. The kit includes a grounding brush and support, rotary grounding ring and a voltage specific contact relay.

Plasma Kits for SE-2PTD

SEO-4560 Plasma Kit 120 VAC
SEO-4562 Plasma Kit 240 VAC

Plasma Kits for SE-4PTD

SEO-4470 Plasma Kit 120 VAC
SEO-4472 Plasma Kit 240 VAC

Plasma Kits for SE-4PD

SEO-4570 Plasma Kit 120 VAC
SEO-4572 Plasma Kit 240 VAC

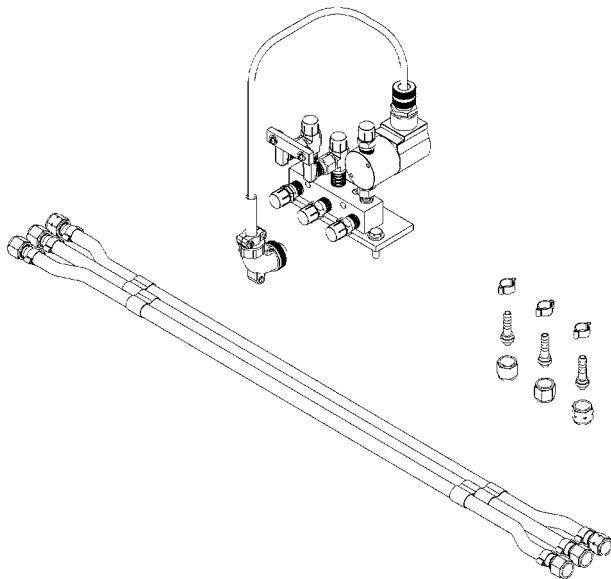

OXY-FUEL KIT:

The Oxy-Fuel Kit enables you to convert the machine to use an oxy-fuel cutting process. The kit includes (2) oxygen hose nuts, (1) fuel gas hose nut, (3) 1/4" hose nipples, (3) hose clamps, 3-hose assembly 5', manifold mounting plate & hardware as well as voltage specific quick acting manifold with solenoid.

SEO-4480 Oxy-Fuel Kit 120 VAC
SEO-4482 Oxy-Fuel Kit 240 VAC

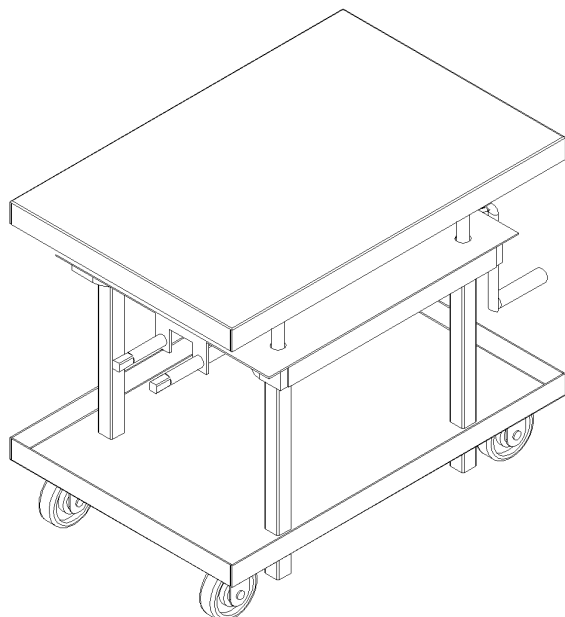

MECHANICAL ELEVATING TABLE:

The Mechanical Elevating Table provides an adjustable mobile surface for the machine to be mounted to. The Mechanical Elevating Table is equipped with (2) fixed and (2) swivel 5" diameter base-wheels and can be raised from a lowered height of 24" to a raised height of 42". A floor lock is provided for holding the table securely in position when in use.

SEO-5486 Mechanical Elevating Table.

MAIN CONTROL PANEL & PROGRAMMING

Main Control Panel

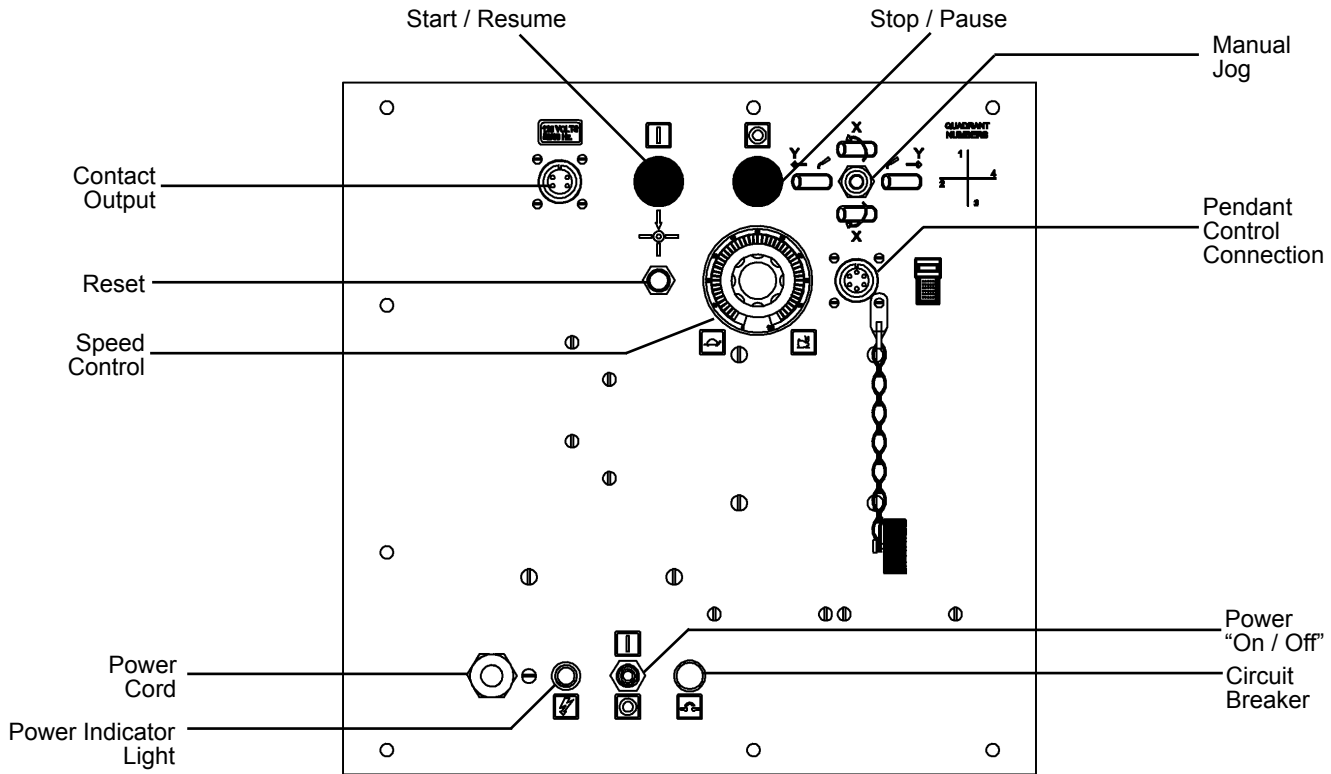

Programming With The Handheld Terminal

To cut a nozzle or hole, the sequence of actions would be to take the handheld terminal connected to the Control Panel and:

1. Press the reset button on the machine. The handheld terminal will display "READY".
2. Press "A" on the terminal. The terminal will ask you what type of cut you want. (See Types 1-5, Page 2).
3. Press the number desired and then press "ENTER".
4. The terminal will ask for the diameter of the small pipe. Press the appropriate dimensions and press "ENTER".
5. The terminal will ask for the diameter of the large pipe. Press the appropriate dimensions and press "ENTER".
6. Enter the offset dimension if cutting a hillside nozzle.
7. Enter the "ANGLE" in degrees if cutting a lateral.
8. Press "START" on the machine to begin to cut.

When using Plasma, press "B" and enter the time delay required (which is stored until changed again.)

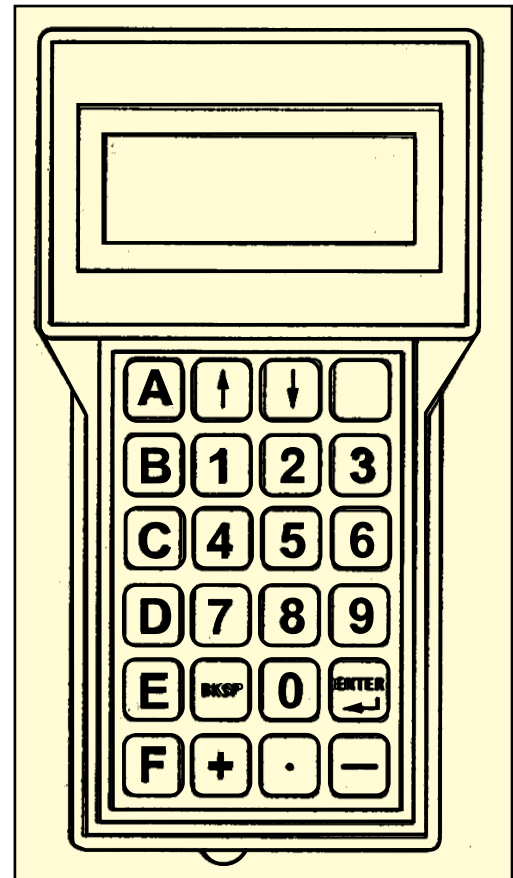

PROGRAMMING CONT'D.

Programming Arbitrary Shapes

For custom shapes select the "shape" software. Programming is simple but will require a few more steps due to all the variations possible.

First, the developed pattern should be laid out as if the pipe is unrolled flat. The cut is then split into a sequence of straight lines or circular arcs that make up the desired pattern.

Next, these should be listed in a table on paper, with the type, quadrant and required dimensions (referring to the chart in the Instruction Manual).

For example, to cut a slot like the one in the diagram, the shape would consist of the six segments shown. The first segment is a clockwise 90° arc, which is Type 1, in quadrant 3 and the required dimension is the radius.

To program the shape, press "A", then enter the total segments at the prompt.

Next, the data for each segment – type, quadrant and dimensions – are entered in turn, at the prompt.

Segment Type and Line Chart									
Quadrant:	#4					TIME DELAY	PERCENT SPEED		
	#3					WAIT FOR START BUTTON	AUXILIARY MODES		
	#2					WELD/OXY OFF	PIPE CUT NUMBER		
	#1					WELD/OXY ON	REPEAT ANOTHER STEP		
		1. Clockwise 90 Deg Arc	2. Counter-Clockwise 90 Deg Arc	3. X or Y Axis Line	4. Oblique Line	5. Functions	6. Functions	7. Clockwise Partial Arc	8. Counter-Clockwise Partial Arc
Segment Types:									
A. All Segments - Build New Shape			B. Reprogram One Segment			C. Change Shape Number			
D. Display Current Shape Data			E. End of Segment Slowdown						

Capabilities

<p>TYPE 1</p> <p>SADDLE NOZZLE CUTS</p>	<p>TYPE 4</p> <p>MITER CUT</p>
<p>TYPE 2</p> <p>OFFSET SADDLE NOZZLE CUTS (Hillside)</p>	<p>TYPE 5</p> <p>HOLE CUTTING AT VARIOUS ANGLES</p>
<p>TYPE 3</p> <p>LATERAL NOZZLE CUTS</p>	<p>SHAPE PROGRAM</p> <p>CUSTOM IRREGULAR SHAPES</p>

ACCESSORIES



CWO-7635 Powermax 1250

Includes the following:

- Interface cable to the Cypress Pipe Cutter
- 50' (15.24 m) Machine Barrel Torch

Power Requirements:

Auto voltage runs on 200-600 Volts, 1 or 3-phase, without the need of rewiring.

Adjustable Output

Current: 25-80 Amps

Cutting Capacity:

(Recommended) 7/8"
(22 mm)

CWO-7636

Consumable Kit for
CWO-7635



BUG-1274

3-Hose Oxy-Acetylene
Machine Torch 10"
(254 mm)

BUG-4072

3-Hose Propane/Natural
Gas Machine Torch 10"
(254 mm)



Oxy-Acetylene Tips

Part No.	Tip Size	Plate Thickness	Oxygen PSIG	Fuel Gas PSIG	Orifice Drill Size
BUG-1270-000	000	Light Gauge to 3/16" (4.8mm)	15-20	5-15	#68
BUG-1270-00	00	3/16"-3/8" (4.8-9.5mm)	20-25	5-15	#64
BUG-1270-0	0	3/8"-5/8" (9.5-15.9mm)	35-40	5-15	#60
BUG-1270-1	1	5/8"-1" (15.9-25.4mm)	35-40	5-15	#56
BUG-1270-2	2	1"-2" (25.4-50.8mm)	40-45	5-15	#52
BUG-1270-3	3	2"-3" (50.8-76.2mm)	45-50	5-15	#48
BUG-1270-4	4	3"-6" (76.2-152.4mm)	50-75	10-15	#42

* For tips to cut 6" to 15" (152.4-381 mm), please consult factory.

Oxy-Propane, Natural Gas Cutting Tips

Part No.	Tip Size	Plate Thickness	Oxygen PSIG	Fuel Gas PSIG	Orifice Drill Size
BUG-4070-000	000	Light Gauge to 3/16" (4.8mm)	15-30	5-15	#68
BUG-4070-00	00	3/16"-3/8" (4.8-9.5mm)	20-30	5-15	#64
BUG-4070-0	0	3/8"-5/8" (9.5-15.9mm)	30-40	5-15	#60
BUG-4070-1	1	5/8"-1" (15.9-25.4mm)	35-50	5-15	#56
BUG-4070-2	2	1"-2" (25.4-50.8mm)	40-55	5-15	#52
BUG-4070-3	3	2"-3" (50.8-76.2mm)	45-60	5-15	#42
BUG-4070-4	4	3"-6" (76.2-152.4mm)	50-75	5-15	#42
BUG-4070-5	5	6"-8" (152.4-203.2mm)	65-80	5-15	#35
BUG-4070-6	6	8"-12" (203.2-304.8mm)	70-90	5-15	#30

CYPRESS WELDING EQUIPMENT, INC.

A DIVISION OF WELD TOOLING CORPORATION

280 Technology Drive • Canonsburg, PA 15317-9564 USA
Telephone: 1-412-331-1776 • 1-800-245-3186 • Fax: 1-412-331-0383

© Weld Tooling Corp. ΧΡΙΣΤΟΣ ROM 1:16
<http://www.cypressweld.com>

SE-2-4PTD-BRO-0310