



CB-3 (CBO-3000) Circle Burner

For straight or beveled flame cut holes on domed heads, vessels and large diameter pipe, without wrap-up of power cable or gas hoses (120/50-60/1).

Mounts on carriage or manipulator.

Features:

- Permanent magnet motor.
- 2-hose machine torch with one tip [Specify Fuel Gas].
- Brushes and collector rings for power supply.
- Rack and pinion adjustment of torch, vertical and horizontal.
- 25ft. (7.6m) control cable.

Capacities:

- For square cut holes: 4"-48" (100-1220 mm).
- For bevel cut holes: 1.5"-42" (40-1060 mm).
- 100% duty cycle.
- 0-7" (0-175 mm) rise and fall cam.
- Rotation speed 3-160 ipm (76-4064 mm/min).

Controls:

- Rotation, FWD-OFF-REV switch.
- Rotation speed control.
- Pre-heat gases.
- Cutting oxygen.
- Pilot light.
- Fuse.

Technical Data:

CB-3 (CBO-3000)

Height: 37" (940 mm)
Net Weight: 170 lbs. (77 kg.)

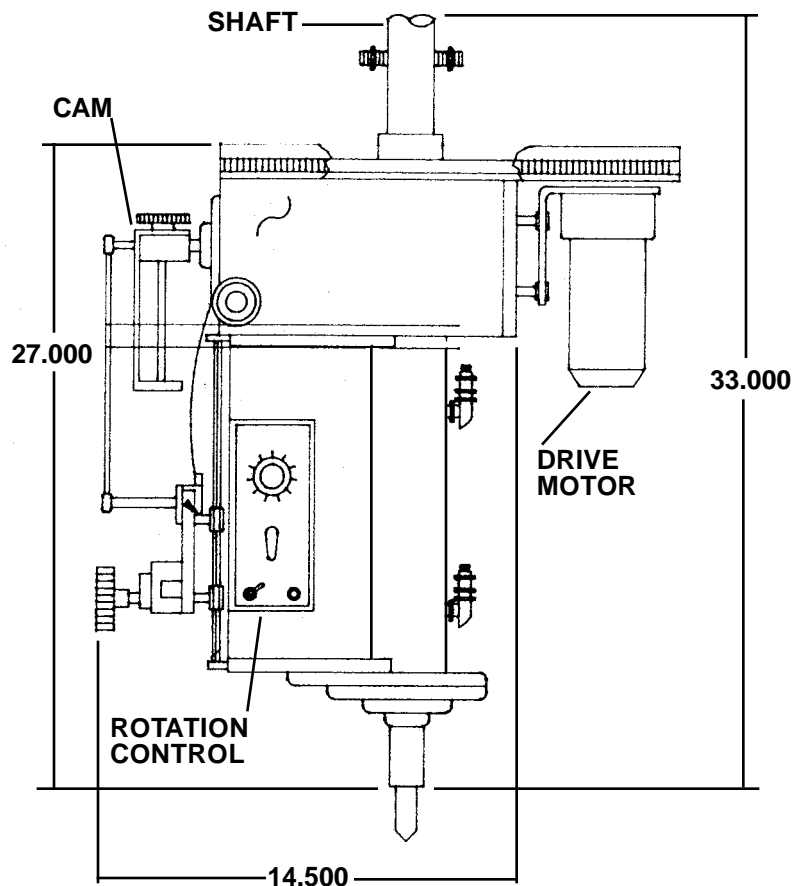
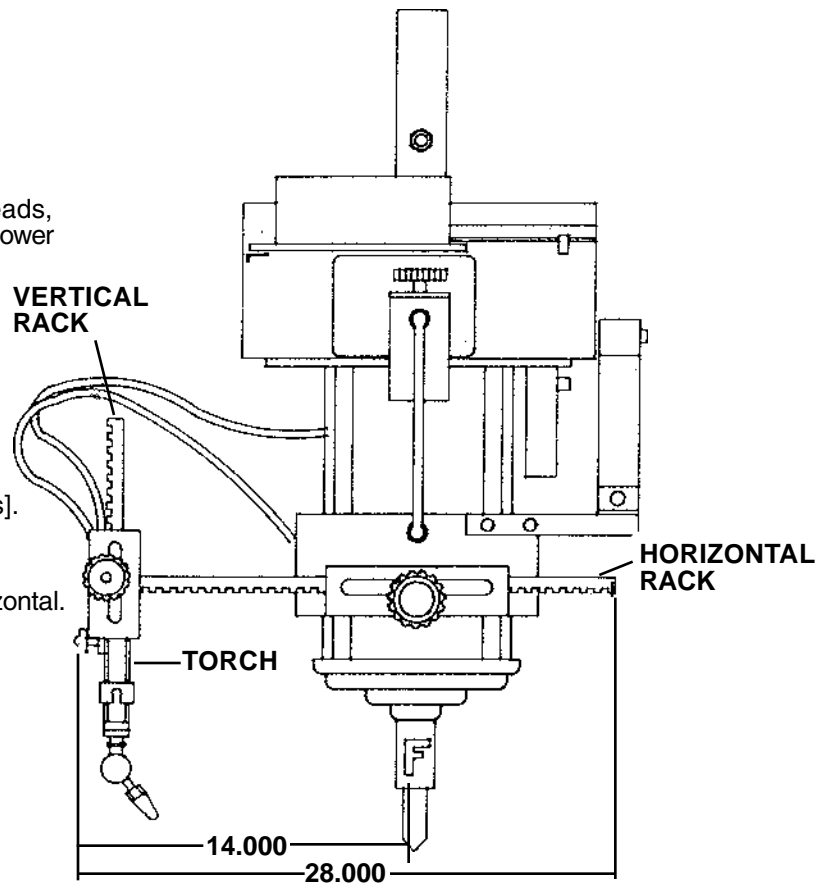



CB-3H (CBO-3010) Circle Burner

For straight or beveled flame cut holes on domed heads, vessels and large diameter pipe, without wrap-up of power cable or gas hoses (120/50-60/1).

Includes hillside attachment for burning on and off centerline holes.

Mounts on column and boom or manipulator.

Features:

Permanent magnet motor.

2-hose machine torch with one tip [Specify Fuel Gas].

Brushes and collector rings for power supply.

Rack and pinion adjustment of torch, vertical and horizontal.

Hillside attachment for burning on and off centerline holes.

Capacities:

For square cut holes: 4"-48" (100-1220 mm).

For bevel cut holes: 1.5".42" (40-1060 mm).

100% duty cycle.

0-7" (0-175mm) rise and fall cam.

Rotation speed 3-160 ipm (76-4064 mm/min).

Controls:

Rotation, FWD-OFF-REV switch.

Rotation speed control.

Pre-heat gases.

Cutting oxygen.

Pilot light.

Fuse.

Technical Data:

CB-3H (CBO-3010)

Height: 37" (940 mm).

Net Weight: 180 lbs. (82 kg.).